

KNX B8-TH Interface

Technical specifications and installation instructions

Item number 70249



1. Description

The **Interface KNX B8-TH** has eight binary inputs and two additional sensor inputs for temperature or temperature and air humidity. They are used to integrate signals and values from conventional buttons and sensors into the KNX building bus.

The application software of the **Interface KNX B8-TH** contains both switch outputs for temperature and humidity as well as PI controllers for heating/cooling and ventilation. The binary inputs can be configured as switches, up/down buttons, dimmers or encoders in various configurations.

Due to its compact design, the interface fits into a switch box. The binary contacts are connected using the cables supplied with the delivery.

Functions:

- **8 binary inputs** (button interfaces for potential-free contacts)
- **1 input for temperature/air humidity sensor TH-UP basic.** Sensors for wall mounting in 55 mm standard frames of switch programmes
- **1 input for temperature sensor T-NTC-ST**
- Bus warning with regard to whether the values for temperature and air humidity are within the comfort field (DIN 1946).
- Dewpoint calculation
- Switch outputs for temperature and air humidity depending on threshold values, adjustable via parameters or communication objects.
- **PI-controller for heating** (one or two-stage) and **cooling** (one or two-stage) according to temperature. Regulation according to separate setpoints or basic setpoint temperature
- **PI controller for humidity** according to humidity: Dehumidifying/humidifying (single level) or dehumidifying (single or double level)
- **4 AND and 4 OR logic gates**, each with 4 inputs. All switching events as well as 16 logic inputs (in the form of communications objects) can be used as inputs for the logic gates. The output of each gate can be configured optionally as 1-bit or 2 x 8-bit

Configuration is made using the KNX software ETS. The **product file** can be downloaded from the Elsner Elektronik website on www.elsner-elektronik.de in the "Service" menu.

1.0.1. Scope of delivery

- Interface
- 2 eight-wire connection lines for binary inputs

1.1. Technical specifications

General:	
Housing	Plastic
Colour	White
Assembly	In-wall
Dimensions W x H x D	approx. 38 mm x 49 mm x 18 mm
Weight	approx. 20 g (interface) approx. 30 g (interface incl. connection lines)
Ambient temperature	-5...+45°C
Ambient humidity	max. 95 % RH, non-condensing
Storage temperature	-30...+85°C
Overvoltage category	III
Degree of contamination	2
KNX bus:	
KNX medium	TP1-256
Configuration mode	S-Mode
Group addresses	max. 254
Assignments	max. 254
Communication objects	254
Nominal voltage KNX	30 V === SELV
Power consumption KNX	10 mA
Connection	KNX plug terminals
Duration after bus voltage restoration until data is received	approx. 5 seconds
Inputs:	

Number	8x binary inputs 1x sensor TH-UP basic, art. no. 30525 1x sensor T-NTC-ST, art. no. 30513
Execution	are at KNX potential (SELV)
Cable length binary inputs	approx. 30 cm, with wire end ferrule 0.14 mm ² , 8 mm long. Maximum cable length: 10 m
Contact voltage	approx. 3,3 V
Contact current	approx. 330 µA
Connection	Connection cable pluggable

The product conforms with the provisions of EU directives.

2. Safety and use instructions

2.1. General installation notes

 Installation, testing, operational start-up and troubleshooting should only be performed by an electrician.

CAUTION! Live voltage!

There are unprotected live components inside the device.

- When planning and installing electrical systems, observe the applicable directives, regulations and provisions of the respective country.
- Ensure that the device or system can be disconnected. During installation, disconnect all cables from the power supply and take safety precautions against unintentional switch-on.
- Do not use the device if it is damaged.
- Take the device or system out of service and secure it against unintentional use, if it can be assumed, that risk-free operation is no longer guaranteed.

The device is only to be used for the intended purpose described in this manual. Any improper modification or failure to follow the operating instructions voids any and all warranty and guarantee claims.

After unpacking the device, check it immediately for possible mechanical damage. If it has been damaged in transport, inform the supplier immediately.

The device may only be used as a fixed-site installation; that means only when assembled and after conclusion of all installation and operational start-up tasks and only in the surroundings designated for it.

Elsner Elektronik is not liable for any changes in norms and standards which may occur after publication of these operating instructions.

3. Installation

3.1. Installation location and preparation

 **The device may only be installed and operated in dry, indoor spaces. Avoid condensation.**

The housing of the device must not be opened.

3.2. Connection

 **For installation and wiring at the KNX connection, the provisions and standards applicable to SELV circuits must be complied with!**

There must be no 230 V wiring in the box where the **Interface KNX B8-TH** is installed.

If a metal support frame is used for the box cover of the **KNX B8-TH** and this is adjacent to another metal support frame that covers a box with 230 V wiring, a basic insulation of at least 4 mm must be ensured between the metal support frame and the **KNX B8-TH** and the associated wiring.

Fig. 1

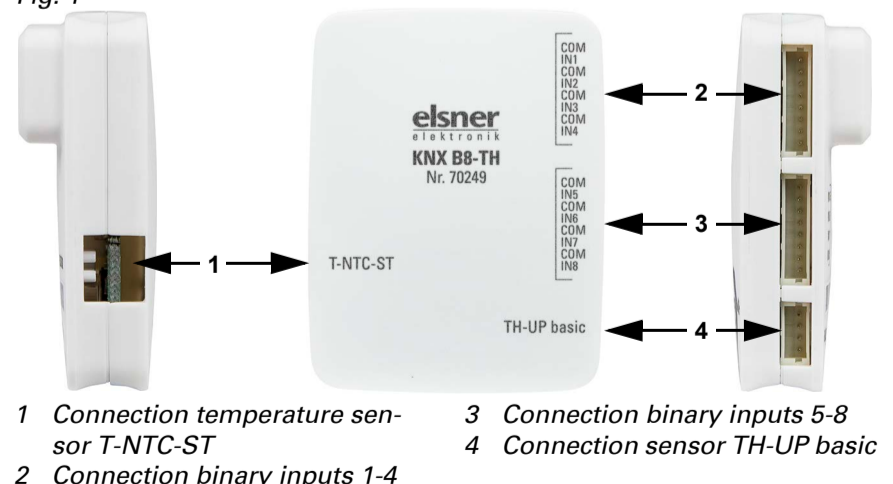

Fig. 2

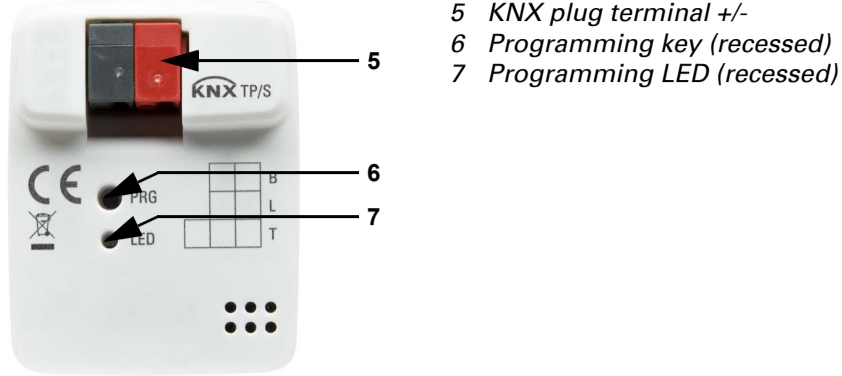
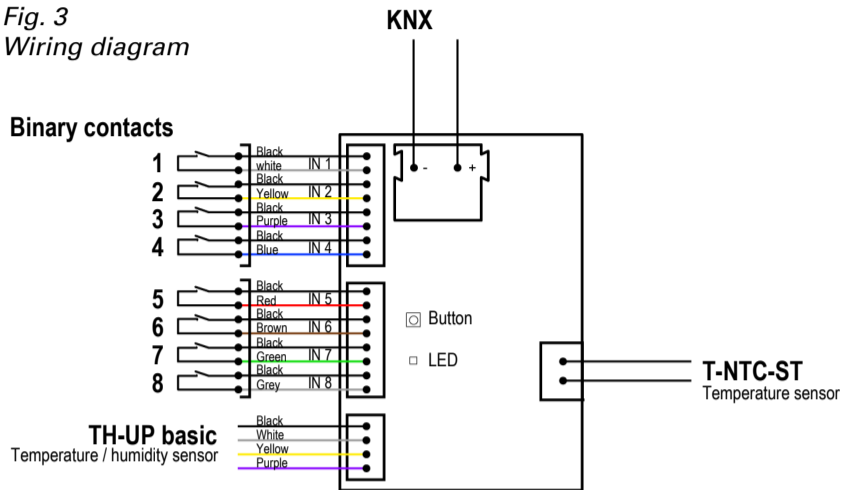

Fig. 3
Wiring diagram



The **Interface KNX B8-TH**: is connected to the KNX data bus with a KNX connection terminal.

⚠ Do not run connection cables for binary inputs and sensors together with 230 V wiring in boxes and connections (pipes)!

Binary contacts are connected to the inputs IN1 to IN8 with the connection lines included in the delivery.

The **temperature and humidity sensor TH-UP basic** (for 55 mm switch programmes) is connected to the input TH-UP basic.

The **temperature sensor T-NTC-ST** (plug/contact sensor) is plugged into the input T-NTC-ST.



Fig. 4
Binary inputs

The device is delivered with connection lines for the binary inputs.

- IN1: black/white
- IN2: black/yellow
- IN3: black/purple
- IN4: black/blue
- IN5: black/red
- IN6: black/brown
- IN7: black/green
- IN8: black/grey

4. Commissioning

After the bus voltage has been applied, the unit will enter an initialisation phase lasting 5 seconds. During this phase no information can be received via the bus.

4.1. Addressing the device

The individual address is assigned via the ETS. For this purpose there is a button with a control LED on the unit (Fig. 2, No. 6+7).

The equipment is delivered with the bus address 15.15.250. Another address can be programmed using the ETS.

5. Disposal

After use, the device must be disposed of in accordance with the legal regulations. Do not dispose of it with the household waste!