

# PRESENCE DETECTOR

## 2 Channels for Lighting and Automation Control

### PD02X01CON

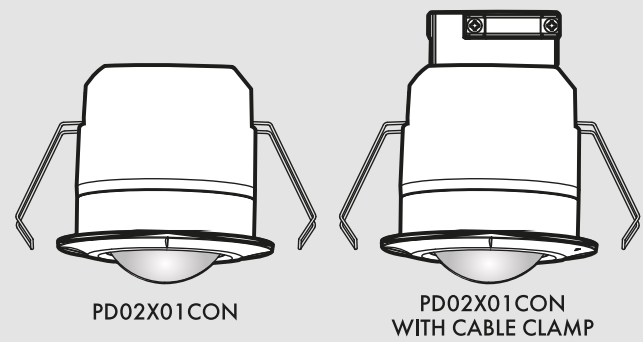

## INSTRUCTION MANUAL

### TECHNICAL SPECIFICATIONS

**Rated voltage** 220-240V~ 50 / 60Hz

#### Load

- **PD02X01CON**
  - Load I (CH1) For Lighting:  $\mu$** 
    - Incandescent Lamp : Max. 2000W
    - AC Halogen Lamp : Max. 1000W
    - LV Halogen Lamp : Max. 1000VA / 600W (traditional)
    - Max. 1000VA / 900W (electronics)
    - Fluorescent Lamp : Max. 1000VA / 600W (uncompensated)
    - Max. 900VA / 100 $\mu$ F
    - 25 x (1 x 18W); 12 x (2 x 18W); 15 x (1 x 36W); 7 x (2 x 36W); 10 x (1 x 58W); 5 x (2 x 58W)
    - LED Lamp : Max. 400W
    - Energy Saving Lamp: Max. 600VA / 400W (include CFL and PL lamp)
  - Load II (CH2) For Automation Control (Lux is invalid):**
    - Max. 5A (cos $\Phi$ =1) for  $\leq$  250VAC
    - Max. 5A for  $\leq$  30VDC
    - Max. 1A (cos $\Phi$ =0.4) for  $\leq$  250VAC

**⚠ Load I (CH1): 230VAC OUT**  
**⚠ Load II (CH2): DRY CONTACT**

### TECHNICAL SPECIFICATIONS

<b>Auto Off Timer Adjustment</b>	Time 1 (for lighting): Adjustable from approx. 5sec to 30min, OFF & $\sqrt{ts}L$ Time 2 (for HVAC): Adjustable from approx. 10sec to 60min
<b>Lux Adjustment</b>	Adjustable from approx. 10Lux to $\infty$ and "☞" (learning range: 10Lux - 2000Lux)
<b>Detection Range</b>	360° circular, up to $\Phi$ 12m at height of 2.5m
<b>Meter Adjustment</b>	Adjustable from approx. "-" ( $\Phi$ 5m) to "+" ( $\Phi$ 12m)
<b>Operating Temperature</b>	-20°C to +50°C
<b>Environmental Protection</b>	IP54

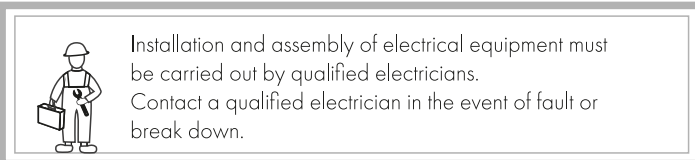

### CAUTION!

- A circuit breaker (250VAC, 10A) type C according to EN60898-1 of load I shall be installed in the fixed wiring for protection.
- A circuit breaker (250VAC, 6A) type C according to EN60898-1 of load II (CH2) shall be installed in the fixed wiring for protection.
- Do not mount on conductive surface.
- Do not open the enclosure frequently.
- Turn off power when change the light sources.
- Always check in-rush current of the connected bulbs before installations: high in-rush current might damage the unit.

## 1 PACKAGE CONTENTS

<b>Pattern</b>			
<b>Item</b>	Detector	Lens shield	Manual
<b>Quantity</b>	1	2	1

## 2 PRODUCT DESCRIPTION

PD02X01CON is a ceiling flush mount PIR detector. The load will be switched on automatically when the movement is detected and the ambient light level is below the Lux setting value. Until there is no movement detected and the pre-set delay time has been expired, load will be switched off automatically. User can pre-set the desired Lux and Time values by VR or IR setting for automatic control lighting on / off with low initial cost and great energy saving potential. PD02X01CON can also be used in many different places for automation control.

They can be widely used in home, office, conference room, classrooms, hotel, corridor, underground parking lots, etc.

### 2.1 Features

- Integrated sensor and power box in one unit using the spring clamps for easy and quick installation.
- Two relays for controlling lighting and Automation control devices respectively.
- Built-in walk test function to ensure the desired detection field is entirely covered and a red LED is built-in for testing triggering indication.
- Ambient light level can be learned as the threshold for switching on / off the loads for more flexible application.
- Lens shield for minimizing or blocking detecting field as user desired.
- IR remote control is available for easy and quick setting.
- Additional function of manually switching on / off the controlled load is available by connecting with a push button switch.

### 2.2 Dimension: (mm)

- **PD02X01CON:**  $\Phi$  80 x 64mm

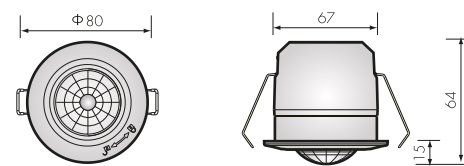

FIG.1-A

## 3 INSTALLATION AND WIRING

**⚠** Please disconnect power completely and read the entire instruction manual carefully before installation.

### 3.1 Select a proper location

3.1.1 It can be installed at the height of 2 - 4m, the recommended installation height is 2.5m to gain the optimal detection pattern, which detection range can reach up to the diameter of 12m and cover 360° detection angle (See FIG.2).

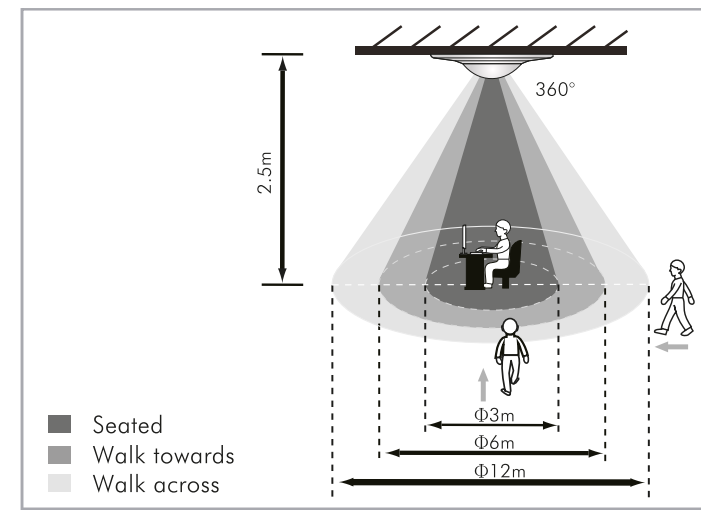

Height	Walk across	Walk towards	Seated
2.0m	$\Phi$ 12m	$\Phi$ 5m	$\Phi$ 2m
2.5m	$\Phi$ 12m	$\Phi$ 6m	$\Phi$ 3m
3.0m	$\Phi$ 14m	$\Phi$ 5m	$\Phi$ 2m
3.5m	$\Phi$ 14m	$\Phi$ 5m	$\Phi$ 1m
4.0m	$\Phi$ 16m	$\Phi$ 5m	-

FIG.2

3.1.2 Pay attention to the walking direction in the test proceeding. It is more sensitive to movement across the detector and less sensitive to movement directly toward to detector which will reduce the detection coverage (See FIG.3).

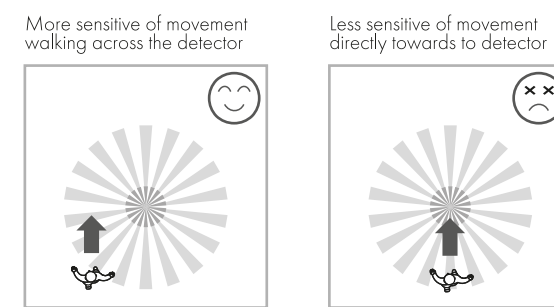

FIG.3

### 3.1.3 Helpful tips for installation

Since the detector is in response to temperature change, please avoid following conditions (See FIG.4-A & FIG.4-B):

- Avoid aiming the detector toward the objects which may be swayed in the wind, such as curtain, tall plants, miniature garden, etc.
- Avoid aiming the detector toward the objects whose surfaces are highly reflective, such as mirror, monitor, etc.
- Avoid mounting the detector near heat sources, such as heating vents, air conditioning, vents as dryers, lights, etc.

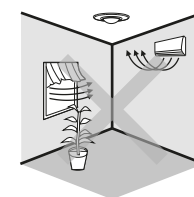

FIG.4-A

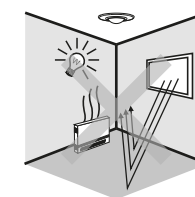

FIG.4-B

### 3.2 Function

#### 3.2.1 Manual on/off switching by using push button to activate R/S terminal

3.2.1.1 An additional push button can be connected between terminal R/S and L for manual on / off operation (case 1: on  $\rightarrow$  off; case 2: off  $\rightarrow$  on). While pressing push button ( $\leq$ 1sec): Please note, this function is invalid when the lighting (detector) is in the On 8hrs & Off 8hrs conditions set by IR remote control.

#### Case 1: Manual off switching (Lux setting is invalid):

Under the light on status, the light can be manually switched off by short pressing ( $\leq$ 1sec) the push button. During this operation mode, once the detector is triggered by movement, the light keeps be off within the set switch off delay time. Until there is no movement detected and the pre-set switch off delay time has reached, the detector resumes to work according to the previous operation mode set by knobs or IR. To press the push button ( $\leq$ 1sec) during the light manual off period will activate the manual light on function (working as the Case 2).

#### Case 2: Manual on switching (Lux setting is invalid):

Under the light off status, the light can be manually switched on by short pressing ( $\leq$ 1sec) the push button. During this operation mode, once the detector is triggered by movement, the light keeps be on within the pre-set switch off delay time. Until there is no movement detected and the pre-set switch off delay time has elapsed, the detector resumes to work according to the previous operation mode set by knobs or IR.

To press the push button ( $\leq$ 1sec) during the light manual on period will activate the manual light off function (working as the Case 1).

### 3.2.2 ON / OFF delay function

According to the changeable ambient light level, detector can postpone delay time of turning on and off load to avoid unnecessary switching due to rapid ambient light change:

**Ambient light level changes from bright to dark:** To avoid unnecessary switching ON/OFF load due to temporary ambient light value change caused via nature, e.g. a passing cloud, the detector has been designed with a 10 seconds delay for activating the light on and the detector will ignore any movement within the 10 seconds delay time, and the red LED will be continuous on as indication, but the detector has no reaction during the 10 seconds delay time.

**Ambient light level changes from dark to bright:** If the ambient light level continuously exceeds the switch off Lux value for 5min, there are different reactions according to the time setting value. Time setting  $\geq$ 5min, the light will be automatically switched off after 5min. Time setting < 5min, the light will be automatically switched off when the set time reached if no movement is detected during the 5min. But if there is movement detected within the 5min, the time will be reset upon detection and until 5min later, the light is switched off.

### 3.3 Wiring

#### 3.3.1 PD02X01CON

3.3.1.1 Normal operation (See FIG.5)

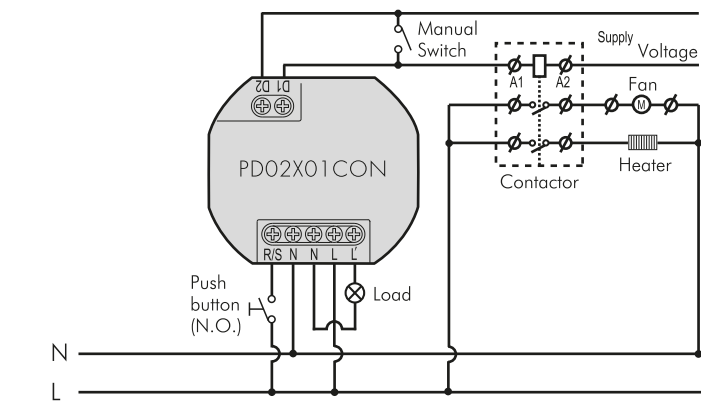

FIG.5

3.3.1.2 Staircase timer switch controlled by one detector (Time1 should be set to  $\sqrt{ts}L$ , See FIG.6)

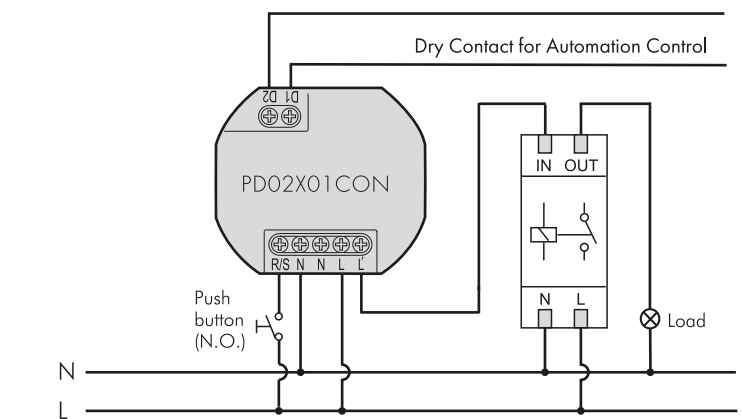

FIG.6

### 3.4 Installation procedure

#### 3.4.1 Ceiling flush mounting

To install detector, please drill a hole in diameter of 68mm on ceiling board and keep the power cable outside. Please strip off 6 - 8mm of cable sheathing for wiring (See FIG. 7).

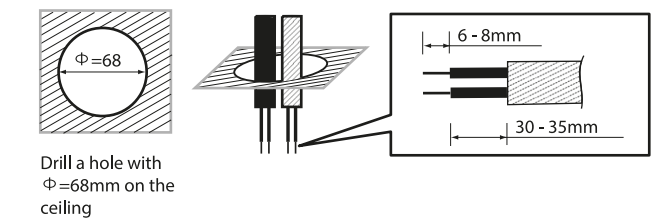

FIG.7

3.4.2 Use screwdriver to break the rubber gasket, then feed cables through it (See FIG. 8).

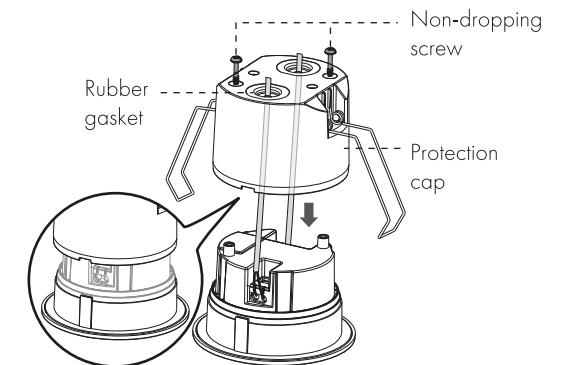

FIG.8

3.4.3 Please refer to illustration of FIG.5 - FIG.6 for correct wiring and get the gap of the protection cap to be aligned with the bulge of housing (See FIG.8), then screw the protection cap and fit on the cable clamp.

3.4.4 For the product with cable clamp, the cable clamp has offered two grooves for holding cables in different diameters (See FIG.9)

	Big groove	Small groove
For round cable of $\Phi$ 5 - $\Phi$ 12.5mm		For round cable of $\Phi$ 3 - $\Phi$ 5mm
For 2 round cables of $\Phi$ 5 - $\Phi$ 6mm		For 2 round cables of $\Phi$ 3mm
For one or two flat cable(s) of 4 x 8mm		

FIG.9

3.4.5 Close up two spring clips of detector and insert detector into the drilled hole on ceiling (See FIG.10).

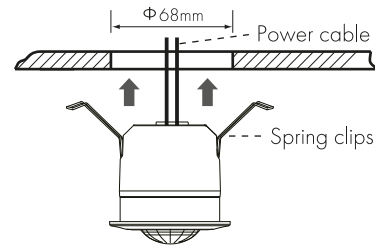

FIG.10

3.4.6 Restore the power supply.

## 4 OPERATION AND FUNCTION

### 4.1 Lux / Time1 and Time2, Meter knob

Knob	Function	Knob setting
	Set the ambient light value for switching on load	Range : Adjustable from approx. 10Lux to ∞. (learn): The actual ambient light level (10Lux - 2000Lux) can be read in.
	Set delay off time for lighting load	Range: Adjustable from approx. 5sec to 30min OFF : Disable CH1 (Load I ) output. √sL : Short impulse mode for staircase timer switch control (Load will be 1sec on, 9sec off)
	Set delay off time for HVAC load	Range: Adjustable from approx. 10sec to 60min (Reaction is regardless of Lux value)
	Set the detection range	Range: Adjustable from approx. "—" (Φ 5m) to "+" Φ 12m

### 4.2 Lux learning function with knob

#### Learning procedure:

- Adjust the knob to "☞" when the ambient light level matches with the desired value (See FIG.11-A).
- When the knob is set to "☛" originally, it should be adjusted to other position more than 1sec, then goes back to "☞" (See FIG.11-B).
- Then the load is off. LED starts to flash slowly indicating entering into learning mode. Learning will be completed within 25 seconds. Afterwards, the LED and load will keep on 5sec or LED flashes quickly for 5sec and load is off to confirm successful learning (See FIG.11-C).
- After learning procedure, the detector returns to AUTO mode with LED and load being off.

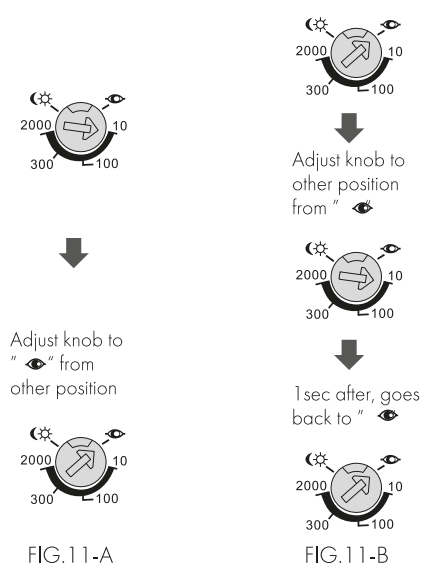

FIG.11-A

FIG.11-B

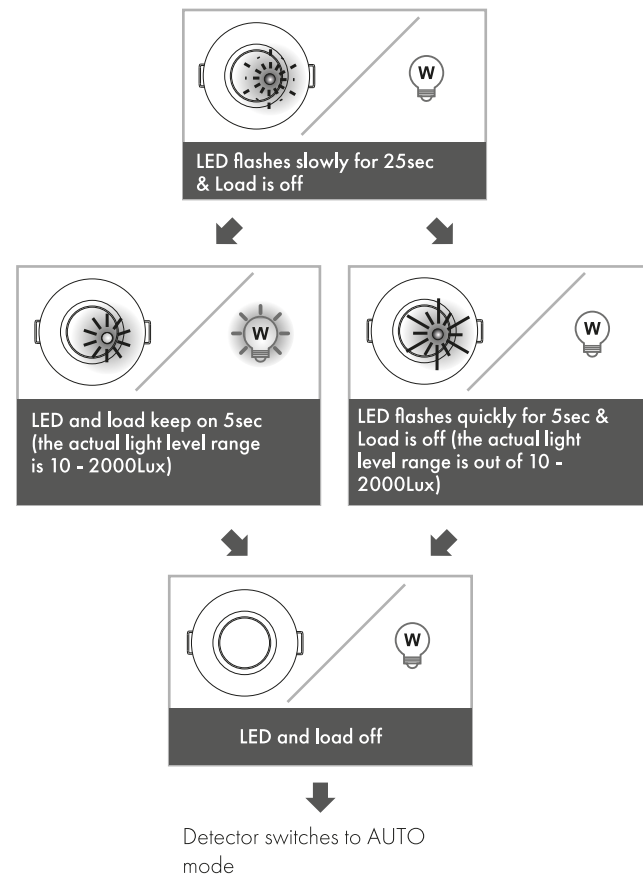

FIG.11-C

#### NOTE

- When the actual light level is out of the range 10 - 2000Lux, detector will learn 25sec, then the red LED flashes quickly for 5sec. When the actual light level is below 10Lux, Lux value is set to 10Lux, or is above 2000Lux, Lux value is set to ∞ (uncontrolled by lux setting).
- Installer should be away from the detector to avoid affecting the luminous flux that reaches the detector when learning Lux value.

### 4.3 Usage of lens shield

4.3.1 PD02X01 CON has provided 2 lens shields for masking the undesired detection area. (See FIG.12-A & FIG.12-B).

Used lens shield	Covered detection range
None	Φ 12m
Small segment	30° per piece
A+B+C	Φ 2m
B+C	Φ 5m
C	Φ 8m

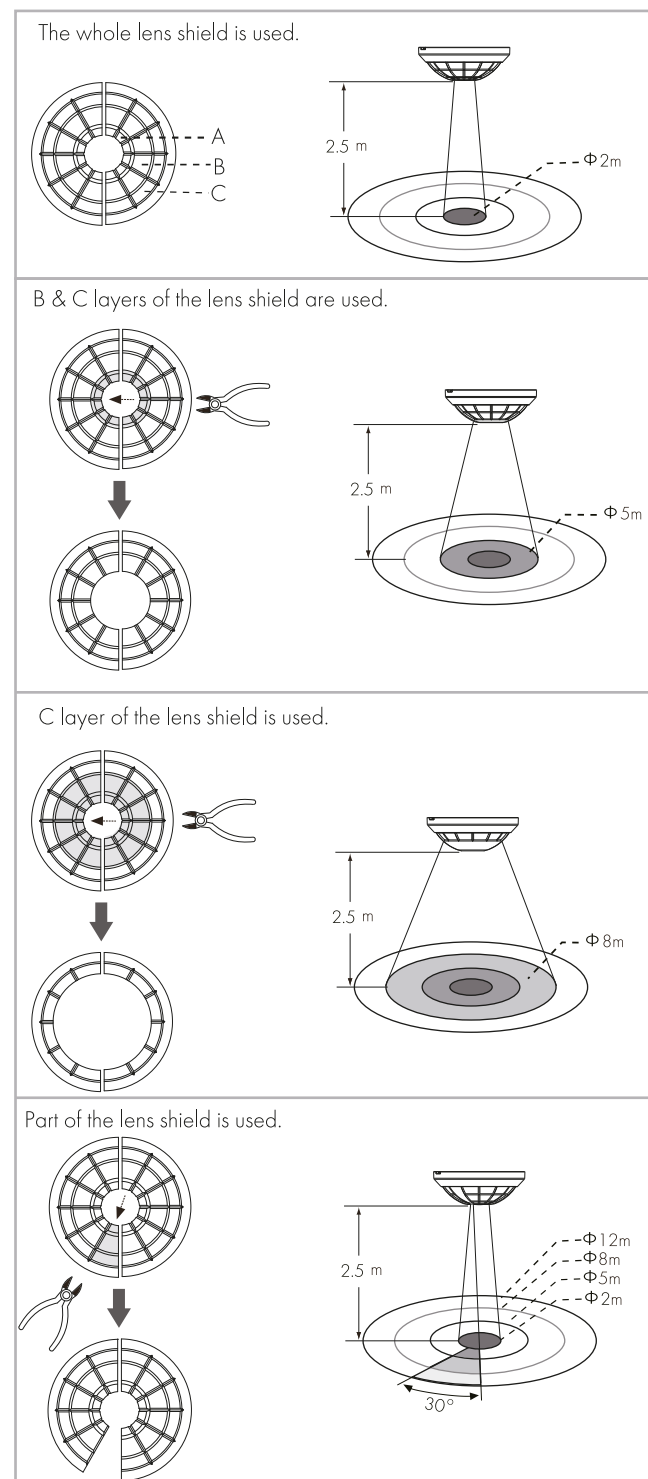

FIG.12

- The shadow part of the lens shields in FIG.12 refers to the cut off parts.

4.3.2 Fixing lens shield: There is circular hook on the back of the decorative frame and the lens shield is designed with a circular groove. The lens shield can be fitted by joining the groove of lens shield with its corresponding hook on the decorative frame (See FIG.13).

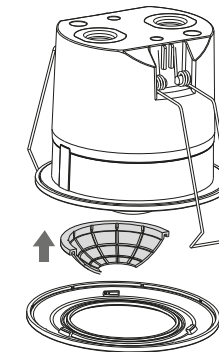

FIG.13

### 4.4 Walk test

The purpose of conducting the walk test is to check and adjust the detection coverage. Set Time1 Knob to "5s" and Lux knob to "☞", Meter knob to "+" then conducting a walk test.

#### NOTE

It takes approx. 60sec for detector to warm up after power is supplied, then enters into normal operation to conduct a walk test.

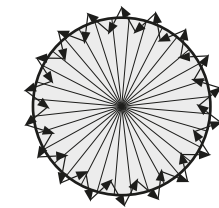

FIG.14

#### Test procedure

- Tester must be within the detection coverage.
- Switch power on.
- PD02X01 CON takes approx. 60sec to warm up with load and LED on, then turns off after warming up time.
- Walk from outside across to the detection pattern until Load turns on for approx. 5sec then off, the next trigger should be Load OFF (See FIG.14).
- Adjust Meter knob and lens shield for desired detection range.
- Repeat step 4.4.4 and 4.4.5 until it meets user's demands.

## 5 TROUBLE SHOOTING

PD02X01 CON work abnormally, please check assumptive problems and suggested solutions in following table that will hopefully solve your problem.

Problem	Possible cause	Suggested solution
Lighting device does not turn on	1. Power does not turn on. 2. Incorrect wiring. 3. Lux knob adjusted incorrectly. 4. Malfunctioned load. 5. Time 1 Knob in OFF position	1. Switch on the power. 2. Refer to wiring diagrams and connect wiring correspondingly. 3. Check if Lux knob is set to the correct position. 4. Replace the disabled load with a new one. 5. Adjust Time 1 Knob - OFF position is to disable CH1
Lighting device does not turn off	1. Auto off time is set too long. 2. Detector is nuisance triggered. 3. Incorrect wiring.	1. Set auto off time to a shorter time and check if the load is switched off or not according to the pre-set off time. 2. Keep be away from detection coverage to avoid activating detector while doing the test. 3. Refer to wiring diagrams and connect wiring correspondingly.
LED does not turn on	Exceeding the detection range.	Walk in the effective detection range of 12m diameter.
Nuisance triggered	There are heat sources, highly reflective objects or any objects which may be swayed in the wind within the detection coverage.	Avoid aiming the detector towards any heat sources, such as air conditionings, electric fans, heaters or any highly reflective surfaces. Make sure there are no swaying objects within the detection coverage.

#### DISPOSAL

The crossed-out bin symbol on the equipment or packaging means the product must not be included with other general waste at the end of its working life. The user must take the worn product to a sorted waste centre, or return it to the retailer when purchasing a new one. An efficient sorted waste collection for the environmentally friendly disposal of the used device, or its subsequent recycling, helps avoid the potential negative effects on the environment and people's health, and encourages the re-use and/or recycling of the construction materials.



PRESENCE DETECTOR  
2 Channels  
for Lighting and  
Automation Control  
**PD02X01 CON**



eeelectron spa  
Via Monteverdi 6  
I-20025 Legnano (MI) - Italia  
Tel: +39 0331 500802 Fax: +39 0331 564826  
Email: info@eeelectron.com Web: www.eelectron.com



MADE IN PRC