



DE Original Montageanleitung – Schlupftürschalter Set  
 EN Translation of the original installation manual – Wicket door switch set  
 FR Traduction de la notice de montage originale – Kit commutateur de portillon  
 IT Traduzione delle istruzioni di montaggio originali – Kit interruttori porta pedonale  
 ES Traducción de las instrucciones de montaje originales – Juego de interruptor para puertas peatonales



Art.-Nr. S11474-00001



SOMMER Antriebs- und Funktechnik GmbH

Hans-Böckler-Straße 27  
 73230 Kirchheim/Teck  
 Germany

+49 (0) 900 1800-150

• 0,14 €/min aus dem deutschen Festnetz. Mobilfunkpreise abweichend.

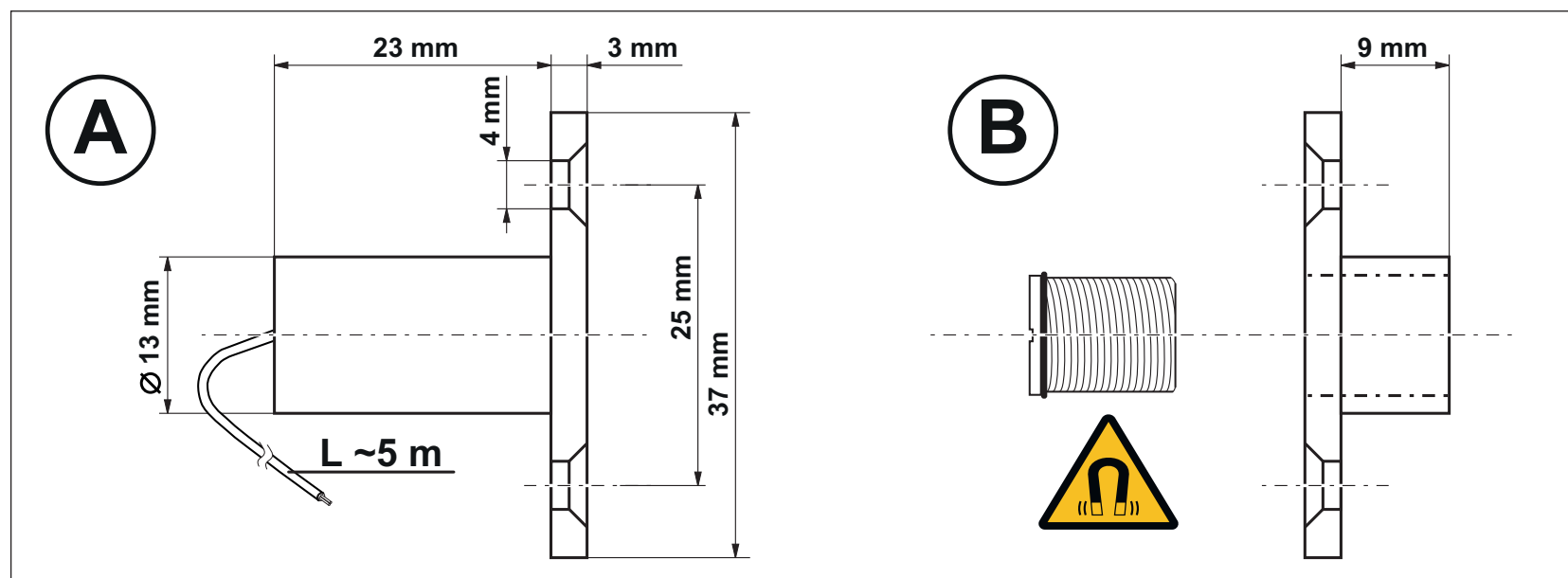
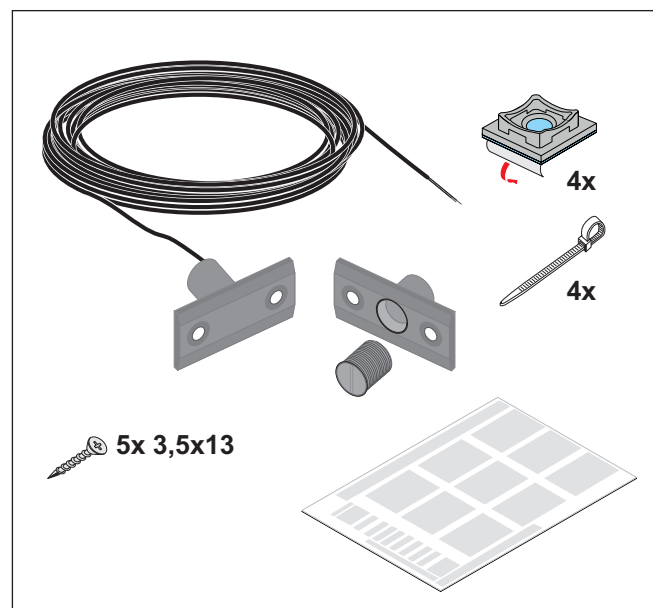
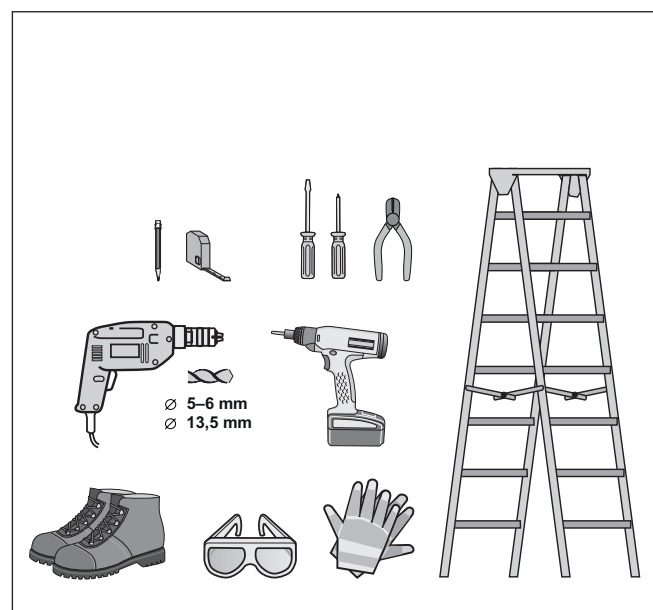

| Technische Daten  | Technical data  | Caractéristiques techniques  | Dati tecnici                                       | Datos técnicos  |                 |
|---|---|--|--|---|-----------------|
| Sicherheitskategorie                                    | Safety category                                       | Catégorie de sécurité  | Classe di sicurezza                                | Categoría de seguridad  | EN 13849-1 *    |
| Schutzart   | IP code   | Indice de protection   | Classe di protezione                               | Índice de protección  | IP68            |
| zulässiger Temperaturbereich                            | Approved temperature range                            | Plage de température adm.  | Intervallo di temperatura ammesso                  | Rango de temperatura admisible                                  | -20 °C...+75 °C |
| Spannungsbereich  | Voltage range   | Plage de tension   | Campo di tensione                                  | Rango de tensión  | 12...24 V AC/DC |
| Kontaktbelastbarkeit max.                               | Max. contact load                                     | Charge admissible max. des contacts                                      | Carico di contatto max. ammissibile                | Resistencia de contacto máx.                                    | 10 mA           |
| Strom max.  | Max. current  | Courant max.   | Corrente max.                                      | Corriente máx.  | 0,1 A           |
| Schaltabstand max.                                      | Max. switching distance                               | Portée max.  | Distanza di commutazione max.                      | Distancia de conmutación máx.                                   | 4 mm            |
| <b>Schnittstelle</b><br>Nur für SOMMER Antriebssysteme! | <b>Interface</b><br>Only for SOMMER operator systems! | <b>Interface</b><br>Uniquement pour les systèmes d'entraînement SOMMER ! | <b>Interfaccia</b><br>Solo per automazioni SOMMER! | <b>Interfaz</b><br>¡Solo para sistemas de accionamiento SOMMER! |                 |
| Schließerkontakt / NO-Kontakt                           | Normally open contact / NO contact                    | Contact à fermeture / contact NO   | Contatto di chiusura / contatto NA                 | Contacto de cierre / contacto NO                                |                 |

- \* Darf nur in Verbindung mit den Garagentorantrieben (S 9050 / S 9060 / S 9080 / S 9110 base<sup>+</sup> / pro<sup>+</sup> / tiga / tiga<sup>+</sup> / A 550 L / A 800 XL), (North America), 2060 / 2080 / 2110 / evo / evo<sup>+</sup> / pro<sup>+</sup>) verwendet werden!
- \* May only be used in combination with the garage door operators (S 9050 / S 9060 / S 9080 / S 9110 base<sup>+</sup> / pro<sup>+</sup> / tiga / tiga<sup>+</sup> / A 550 L / A 800 XL), (North America), 2060 / 2080 / 2110 / evo / evo<sup>+</sup> / pro<sup>+</sup>)!
- \* Ne peut être utilisé qu'avec les automatismes de porte de garage (S 9050 / S 9060 / S 9080 / S 9110 base<sup>+</sup> / pro<sup>+</sup> / tiga / tiga<sup>+</sup> / A 550 L / A 800 XL), (North America), 2060 / 2080 / 2110 / evo / evo<sup>+</sup> / pro<sup>+</sup>) !
- \* Da utilizzare solo in abbinamento con le automazioni per porte da garage (S 9050 / S 9060 / S 9080 / S 9110 base<sup>+</sup> / pro<sup>+</sup> / tiga / tiga<sup>+</sup> / A 550 L / A 800 XL), (North America), 2060 / 2080 / 2110 / evo / evo<sup>+</sup> / pro<sup>+</sup>)!
- \* ¡Únicamente puede utilizarse en combinación con los automatismos para puertas de garaje (S 9050 / S 9060 / S 9080 / S 9110 base<sup>+</sup> / pro<sup>+</sup> / tiga / tiga<sup>+</sup> / A 550 L / A 800vXL), (North America), 2060 / 2080 / 2110 / evo / evo<sup>+</sup> / pro<sup>+</sup>)!

Art.-Nr. S11326-00000\_422022\_0-DRE\_Rev-D\_DE

Contact info:  
 Coordonnées:  
 Informazioni di contatto:  
 Información de contacto:

info@sommer.eu  
 www.sommer.eu

© Copyright 2022  
 Alle Rechte vorbehalten.  
 All rights reserved.  
 Tous droits réservés.  
 Tutti i diritti riservati.  
 Reservados todos los derechos.



DE Original Montageanleitung – Schlupftürschalter Set  
EN Translation of the original installation manual – Wicket door switch set  
FR Traduction de la notice de montage originale – Kit commutateur de portillon  
IT Traduzione delle istruzioni di montaggio originali – Kit interruttori porta pedonale  
ES Traducción de las instrucciones de montaje originales – Juego de interruptor para puertas peatonales

